

IMPORTANT! KEEP FOR FUTURE REFERENCE: READ CAREFULLY.

Be aware of the risks posed by open fire and other heat sources such as electric or gas heaters etc. near the bed.

Warning! Before starting the assembly, please check all the elements. If any parts are damaged, please do not assemble the bed, and notify us of the damaged parts immediately by email, with photos, so that we can send you replacement parts. Once the bed has been assembled, any complaint regarding damages parts will no longer be accepted.

UK

Warning! Do not leave anything in the bed or place the bed near any other equipment that could support the foot or pose a risk of suffocation or hanging the child, such as cords, curtain / blind cords.

Warning! Do not use more than one mattress in the bed.

Recommended maximum mattress thickness of 9 cm - 12 cm.

The selected bed size is the size of the mattress to be used.

It is recommended that all assembly elements be tightened well during assembly, regularly checked and tightened if necessary.

VIKTIGT! BEHÅLL FÖR FRAMTIDA REFERENS. LÄS NOGGRANT.

Var medveten om riskerna med öppen eldoch andra värmekällor såsom elektronik, gasolvärmare etc. nära sängen.

Warning! Kontrollera alla delar innan monteringen påbörjas. Om några delar är skadade, montera inte sängen, och meddela oss om de skadade delarna omedelbart via e-post, med bilder, så att vi kan skicka ersättningsdelar till dig.

SE

När sängen har monterats, kommer reklamationer angående skador på delar inte längre att acceptera

Warning! Lämna inte något i sängen och placera inte sängen nära någon annan utrustning som kan utgöra en risk för kvävning eller hängning av barnet, såsom snören, gardin- / persiennsnören.

Warning! Använd inte mer än en madrass i sängen.

Rekommenderad maximal madrassstjocklek på 9 cm - 12 cm.

Den valda sängstorleken är storleken på den madrass som ska användas.

Det rekommenderas att alla monteringsdelar dras åt ordentligt under monteringen, kontrolleras regelbundet och dras åt vid behov.

VIKTIG! BEHOLD FOR FREMTIDIG REFERANSE. LES NØYE.

Vær oppmerksom på risikoen ved åpen ildog andre varmekilder som elektriske ovner eller gassvarmere etc. i nærheten av sengen.

Advarsel! Kontroller alle delene før du begynner monteringen. Hvis noen deler er skadet, vennligst ikke sett sammen sengen, og gi oss beskjed om de skadete delene umiddelbart på e-post, med bilder, slik at vi kan sende deg reservedeler. Etter at sengen er montert, vil ikke lenger reklamasjoner på skadete deler bli akseptert.

NO

Advarsel! Ikke la noe ligge i sengen, og plasser heller ikke sengen i nærheten av annet utstyr som kan støtte foten eller utgjøre en fare for kvelning eller henging av barnet, for eksempel snorer, gardin-/persiennsnorer.

Advarsel! IKKE bruk mer enn én madrass om gangen.

Anbefalt maksimal madrassstykkel på 9 cm - 12 cm.

Den valgte sengestørrelsen er størrelsen på madrassen som skal brukes.

Det anbefales at alle deler strammes godt under monteringen, kontrolleres jevnlig og etterstrammes ved behov.

VIGTIGT! GEM TIL FREMTIDIG REFERENCE. LÆS GRUNDIGT.

Vær opmærksom på de risici, der er forbundet med åben ild og andre varmekilder, såsom elektriske radiatorer eller gasvarmere og lignende, i nærheden af sengen.

Advarsel! Inden montering skal du kontrollere alle delene. Hvis dele er beskadigede, skal du ikke montere sengen.

Du skal straks kontakte os, og underrette os om de beskadigede dele via e-mail med fotos, så vi kan sende nye dele til dig. Når sengen er monteret, accepteres klager over beskadigede dele ikke længere.

Advarsel! Efterlad ikke noget i sengen, og placér ikke sengen i nærheden af noget, der kan bruges til at klatre på eller udgøre en risiko for kvælning, såsom ledninger, snore, gardin-/persiennesnore og lignende.

Advarsel! Brug ikke mere end én madras i sengen ad gangen.

Den anbefalede maksimale madrastykkelse er 9-12 cm.

Madrassens størrelse skal passe til sengen.

Det anbefales, at alle monterings-elementer strammes godt under monteringen, kontrolleres regelmæssigt og strammes efter ved behov.

DK

TÄRKEÄÄ! SÄILYÄ NÄMÄ OHJEET TULEVAA KÄYTTÖÄ VARTEN. LUE OHJEET HUOLELLISESTI LÄPI.

Ole tietoinen sängyn lähellä olevan avotulen ja muiden lämmönlähteiden, kuten sähkö- ja kaasulämmittimien aiheuttamista riskeistä.

Varoitus! Tarkista kaikki tuotteen osat ennen kokoamista. Älä kokoa sänkyä, jos jokin osa on vaurioitunut. Ota meihin välittömästi yhteyttä ja liitä viestiisi kuvat vaurioituneista osista, jotta voimme lähettää sinulle varaosia. Kun sänky on koottu, vaurioita koskevia reklamaatioita ei enää hyväksytä.

Varoitus! Älä jätä sänkyyn tavaroita, joita lapsi voi käyttää jalansijana. Varmista, ettei sängyn lähellä ole naruja, nauhoja tai verhoja, joihin lapsi voi kuristua.

Varoitus! Älä käytä useampaa kuin yhtä patjaa kerrallaan.

Suosittelava patjan enimmäispaksuus on 9–12 cm.

Patjan on oltava yhtä suuri kuin sänky.

Varmista, että kaikki sängyn kiinnitysosat on kiristetty kunnolla. Tarkista osat säännöllisesti ja kiristä niitä tarvittaessa.

FI

WICHTIG! FÜR ZUKÜNFTIGES NACHSCHLAGEN AUFBEWAHREN: GRÜNDLICH DURCHLESEN.

Beachten Sie die Gefahren durch offenes Feuer und andere Wärmequellen wie z. B. Elektro- oder Gasheizungen etc. in der Nähe des Bettes.

Achtung! Bevor Sie mit der Montage beginnen, überprüfen Sie bitte alle Elemente. Sollten Teile beschädigt sein, bauen Sie das Bett bitte nicht zusammen und melden Sie uns die beschädigten Teile umgehend per E-Mail mit Fotos, damit wir Ihnen Ersatzteile zusenden können. Nach der Montage des Bettes ist eine Reklamation bezüglich beschädigter Teile nicht mehr möglich.

Achtung! Lassen Sie nichts im Bett liegen und stellen Sie das Bett nicht in die Nähe anderer Gegenstände, die als Fußstütze genutzt oder eine Erstickungs- bzw. Erhängungsgefahr für das Kind darstellen könnten, wie beispielsweise Kordeln, Vorhang-/Jalousieschnüre.





Achtung! Verwenden Sie nicht mehr als eine Matratze im Kinderbett.



Empfohlene maximale Matratzendicke von 9 cm – 12 cm.

Die gewählte Matratze sollte der Bettgröße entsprechen.

Es wird empfohlen, bei der Montage sämtliche Montageelemente gut festzuziehen, regelmäßig zu kontrollieren und ggf. nachzuziehen.

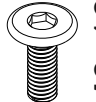
DE

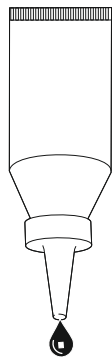
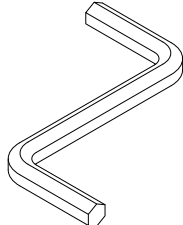
120	100	080	035	017
 M6x120	 M6x100	 M6x80	 M6x35	 M6x16
2-4x	9x	16x	4x	2x

001	002	006
		
2x		4x

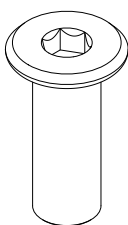
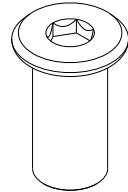
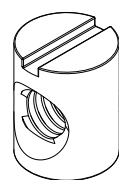
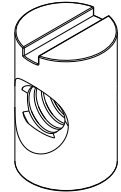
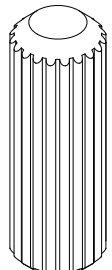
025	018	013	015	010
				 ø10x30
6-8x	2x	24x	1x	20x

6

A

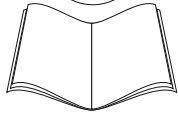

11-14

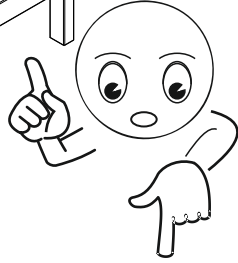
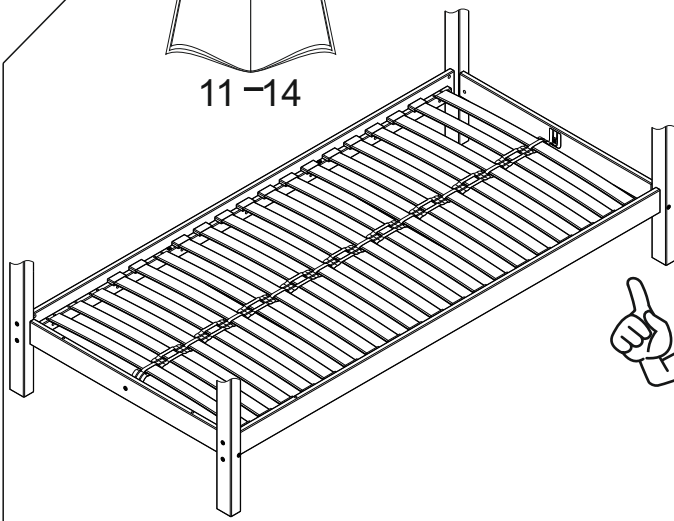

B

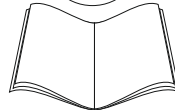

15

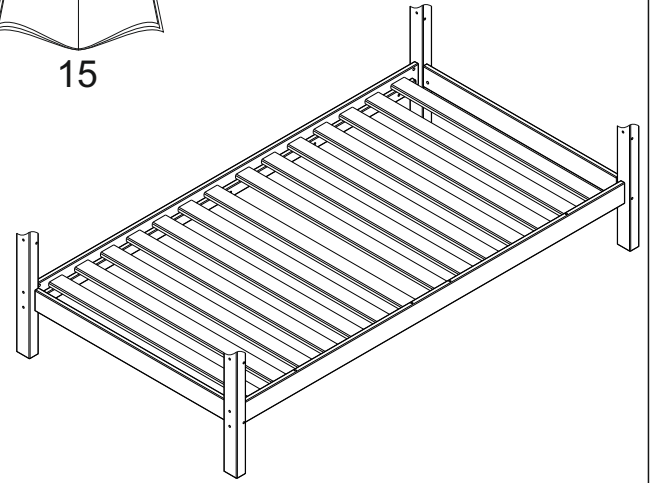

120cm-140cm

035	025	017	018
4x	4x	2x	2x

	140cm	160cm	180cm	190cm	200cm
--	-------	-------	-------	-------	-------

055		28x	32x	36x	38x	40x
-----	--	------------	------------	------------	------------	------------

095		14x	16x	18x	19x	20x
-----	--	------------	------------	------------	------------	------------

092		×	1x	1x	1x	1x
-----	--	---	-----------	-----------	-----------	-----------

091		×	2x	2x	2x	2x
-----	--	---	-----------	-----------	-----------	-----------

	(60cm)	70cm-100cm
--	---------------------	-------------------

	190cm	200cm	
098		14x	15x
033		56x	60x

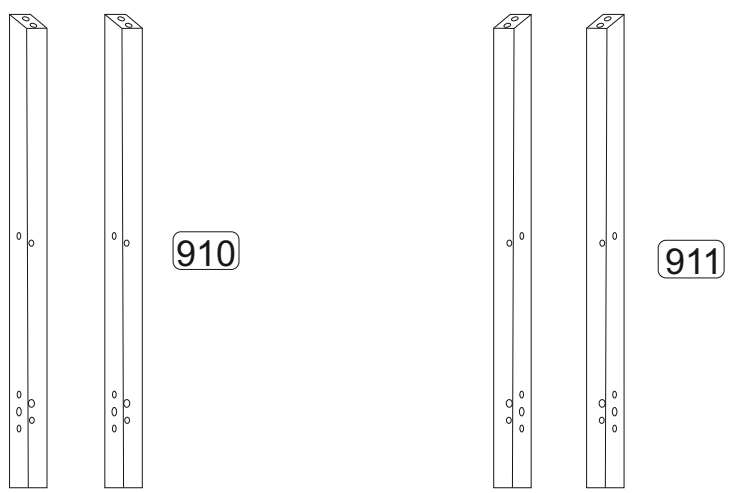
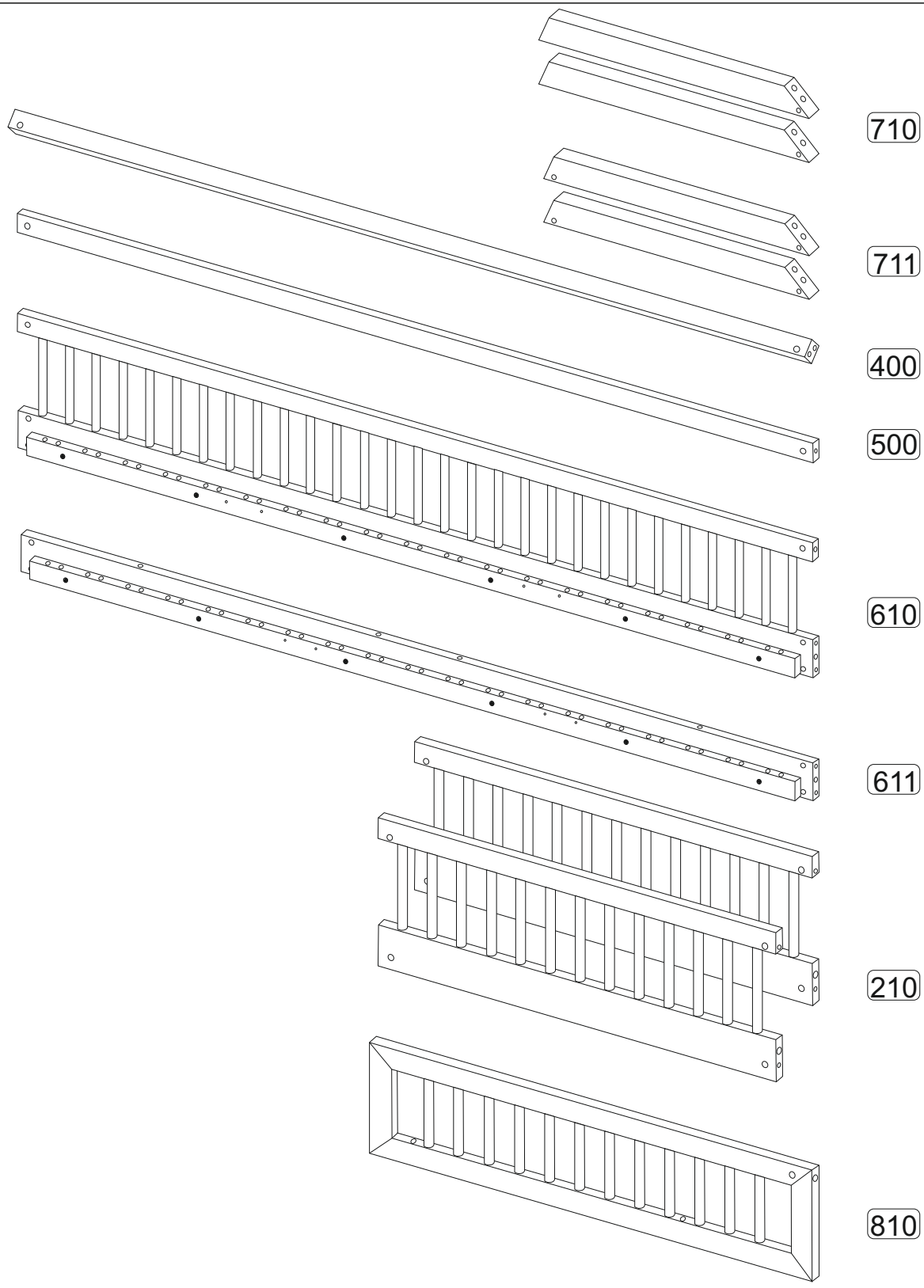

8

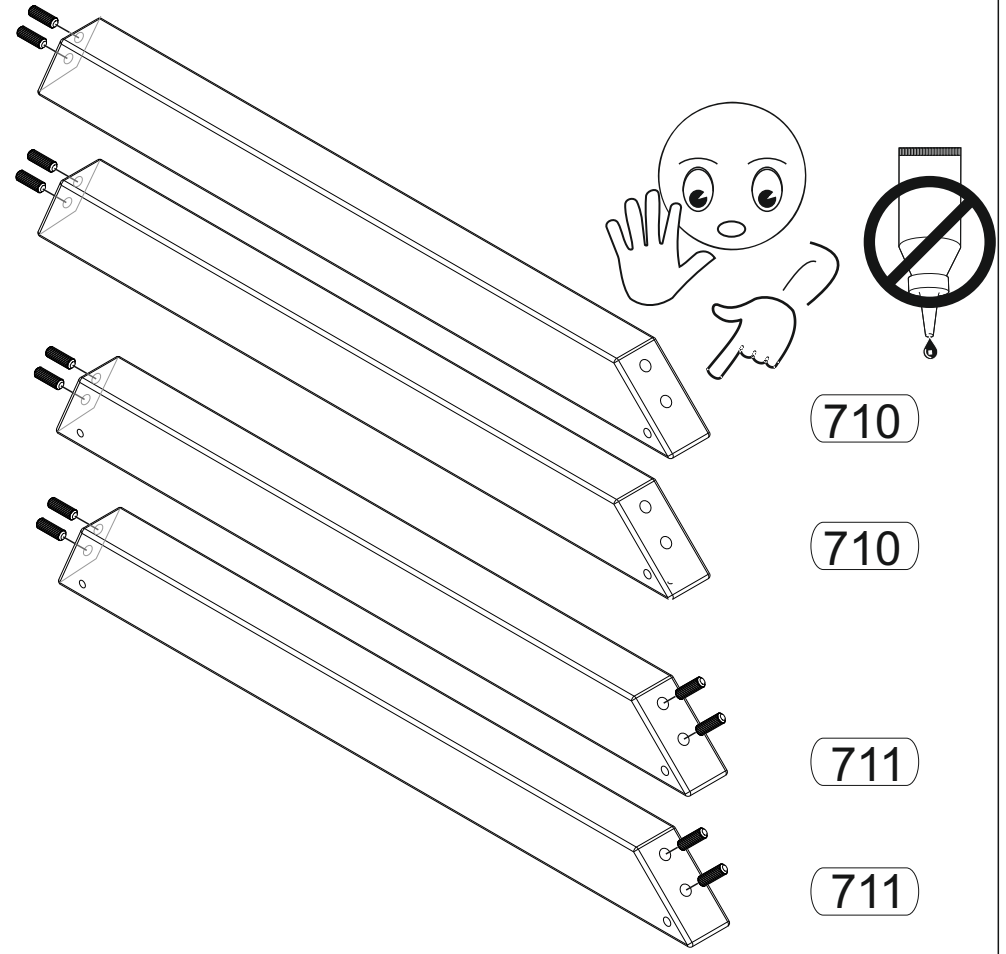
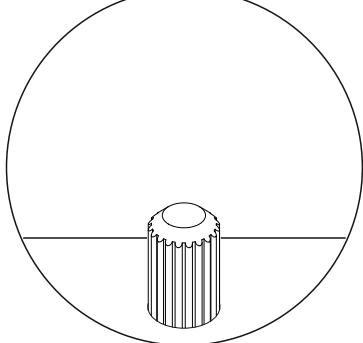
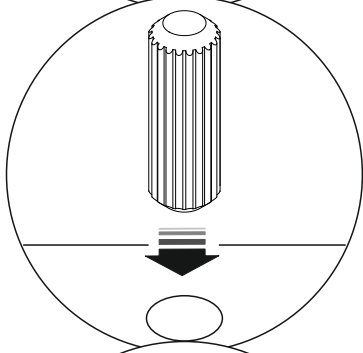
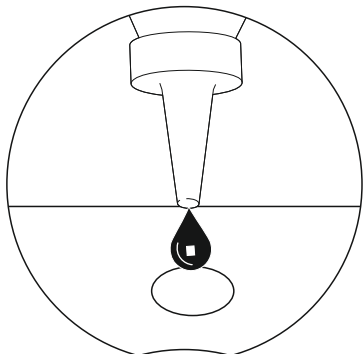
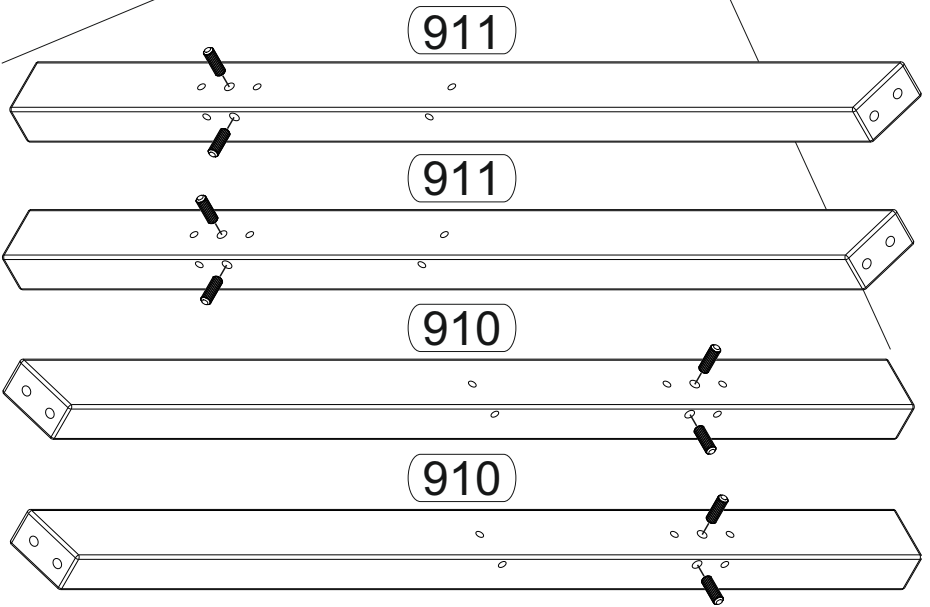
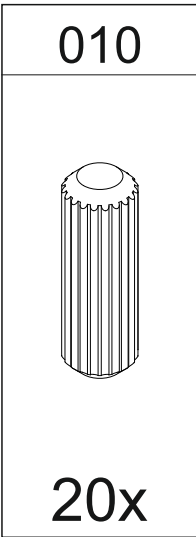
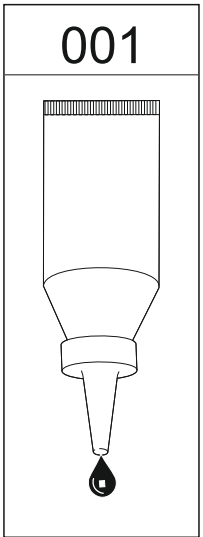
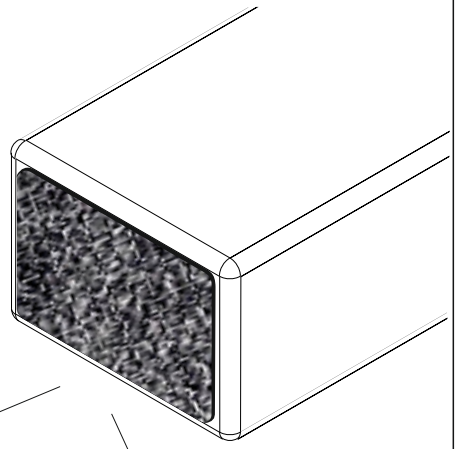
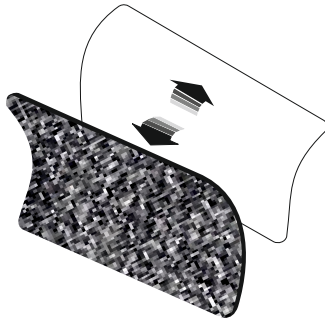

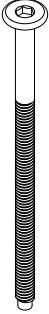
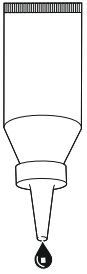
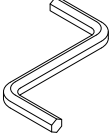
013	100	001	002
			
8x	8x		

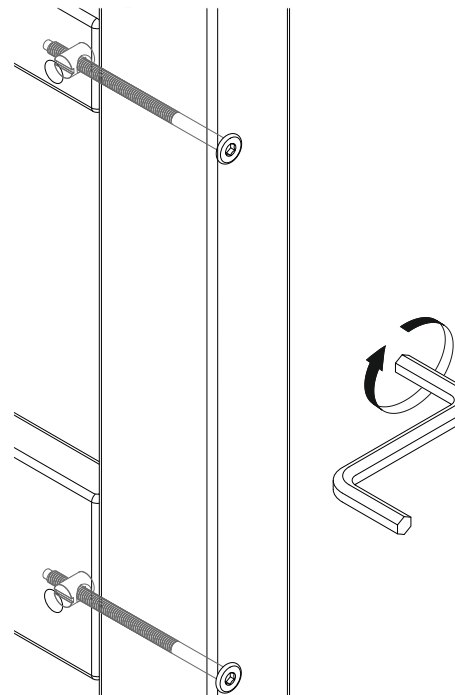
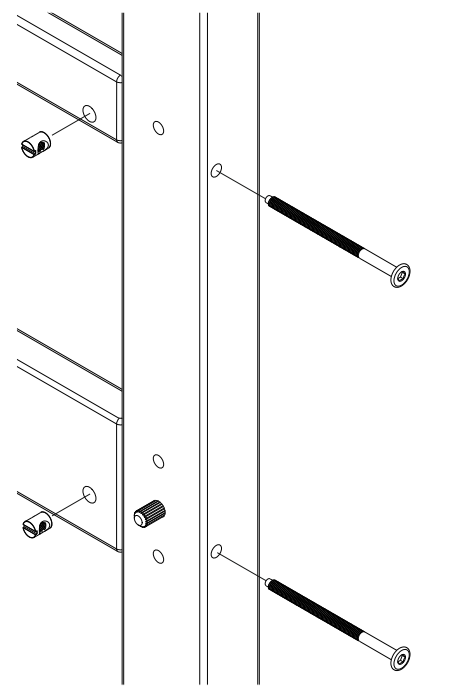
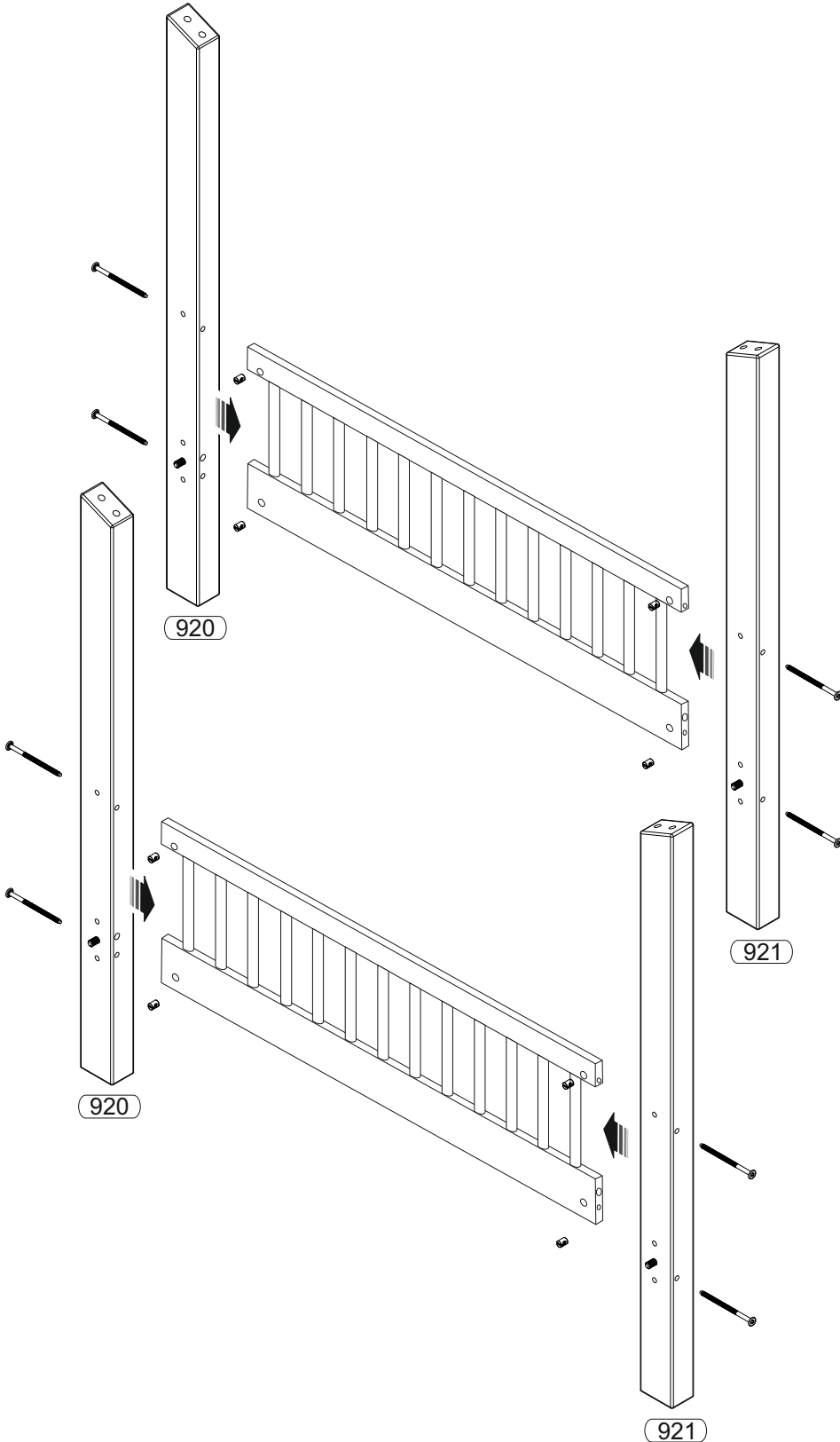
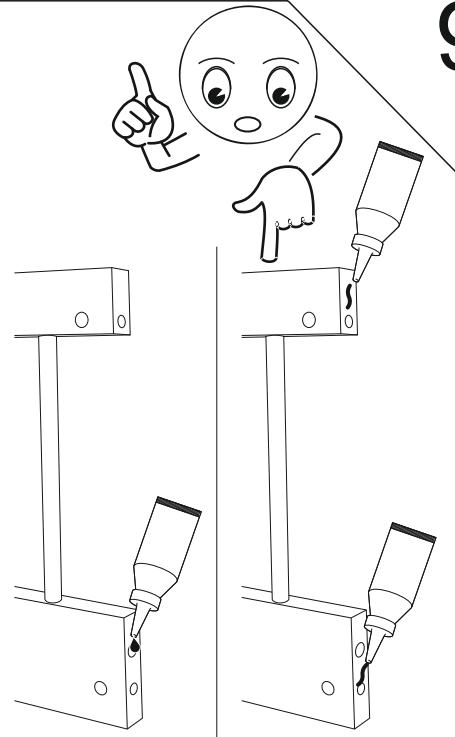

10

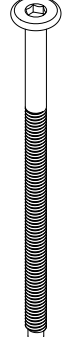
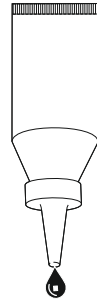
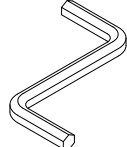
013	080	001	002
			
10x	10x		

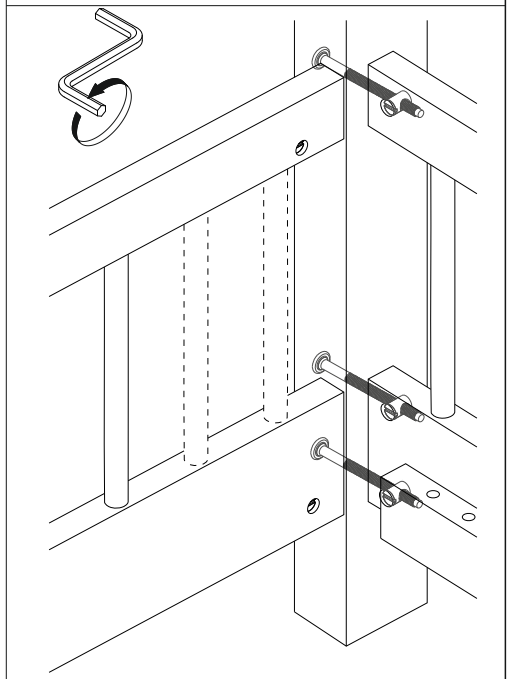
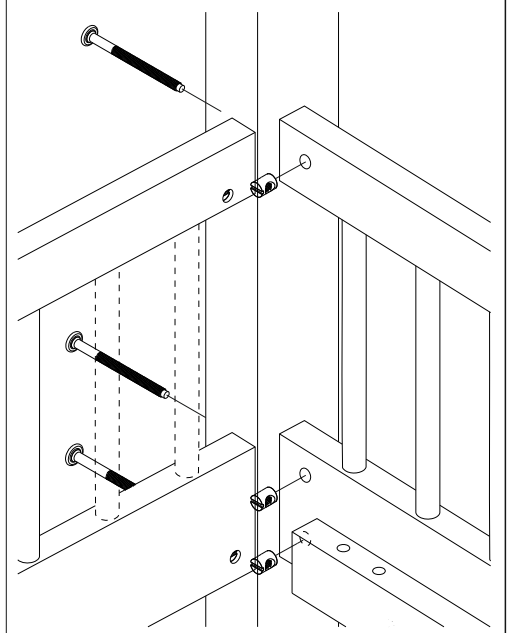
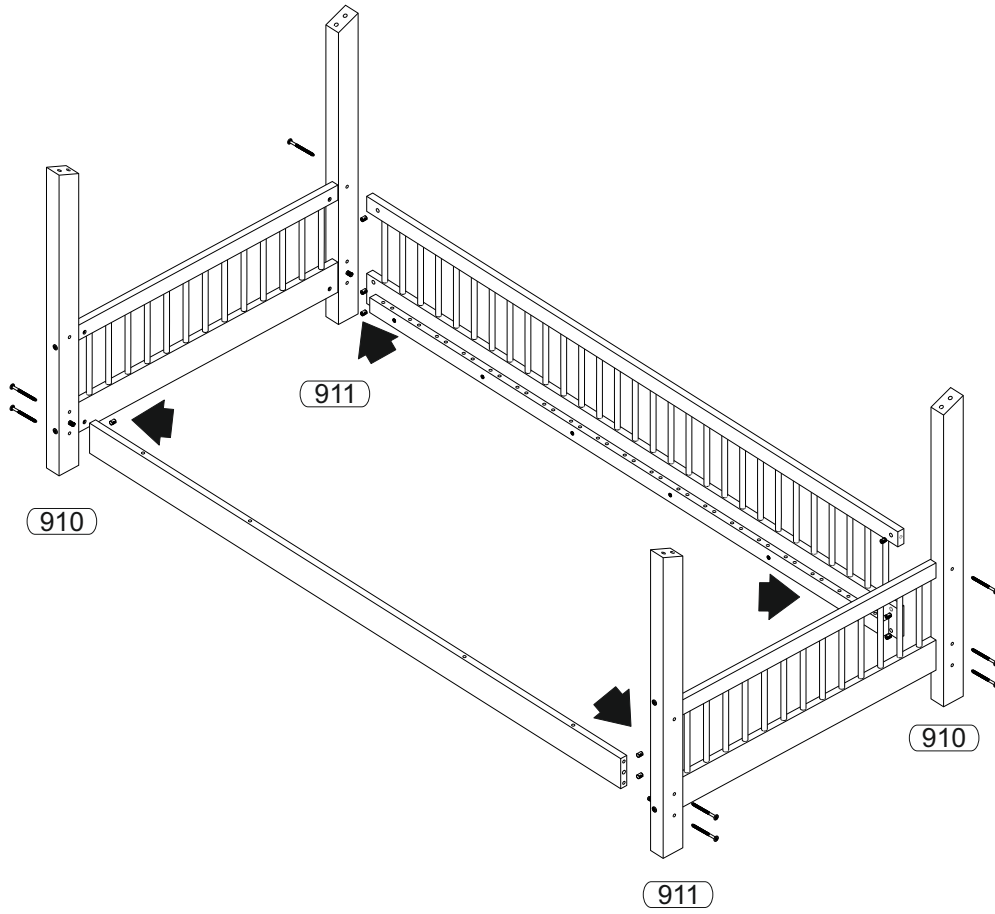
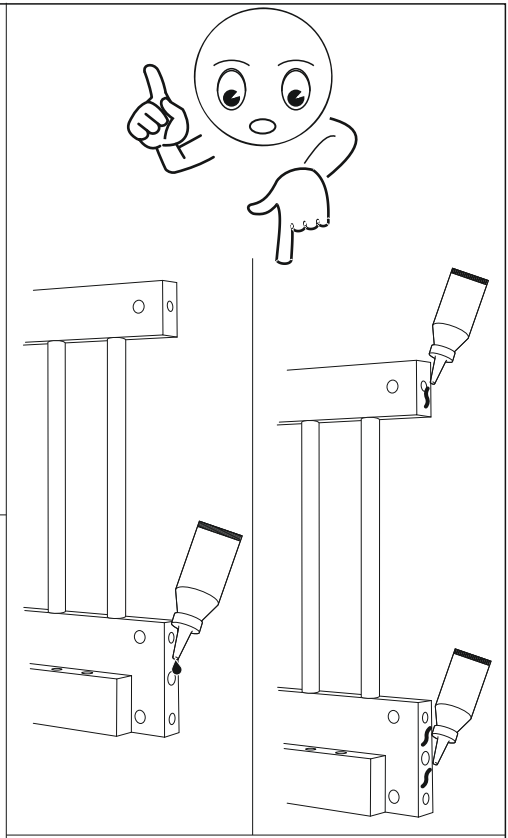

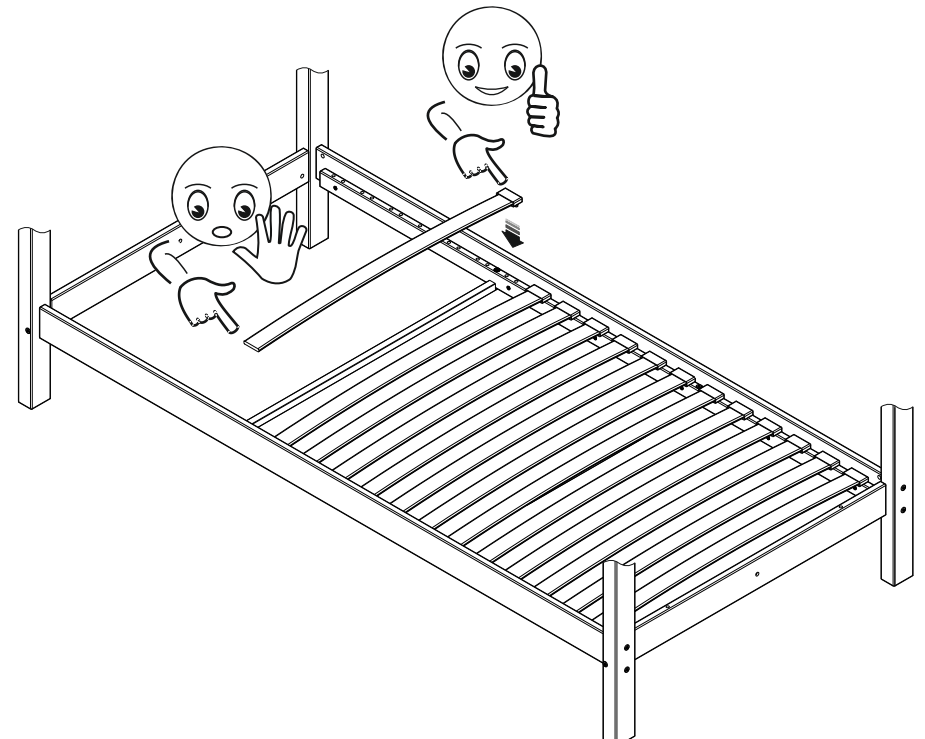
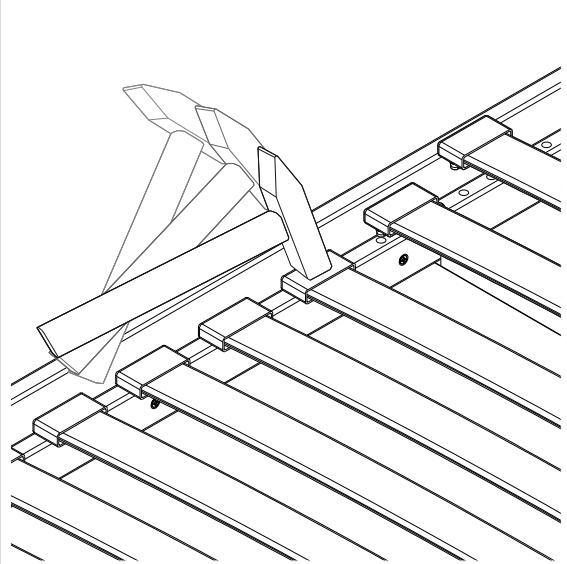
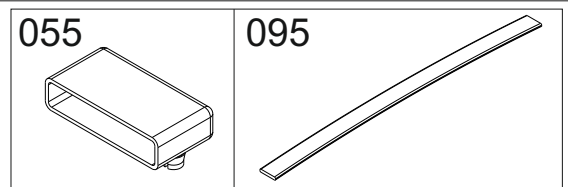
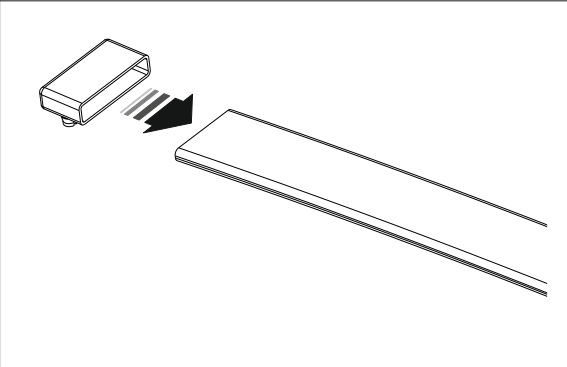
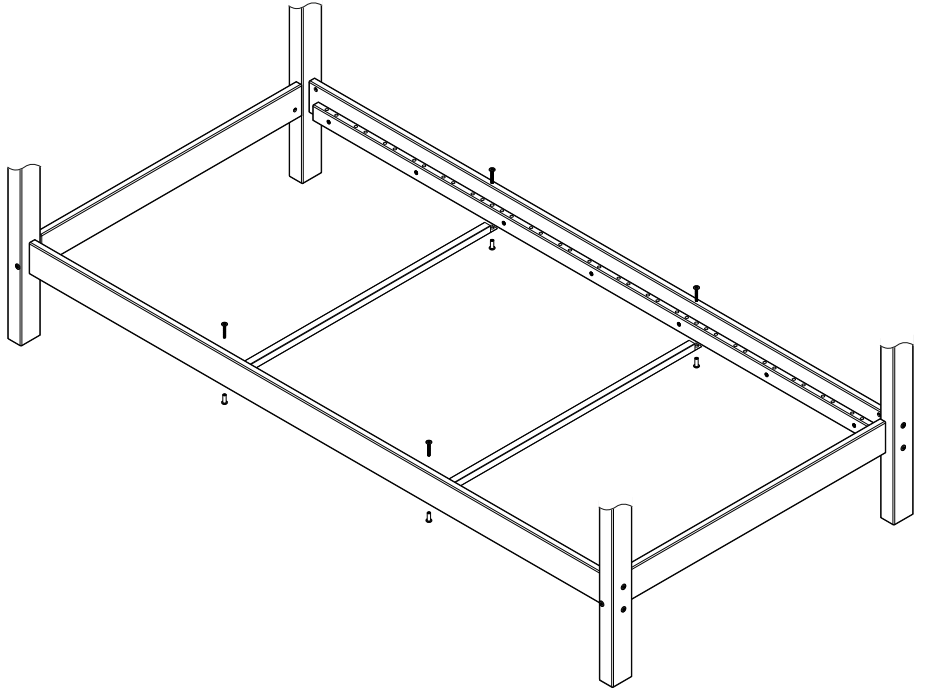
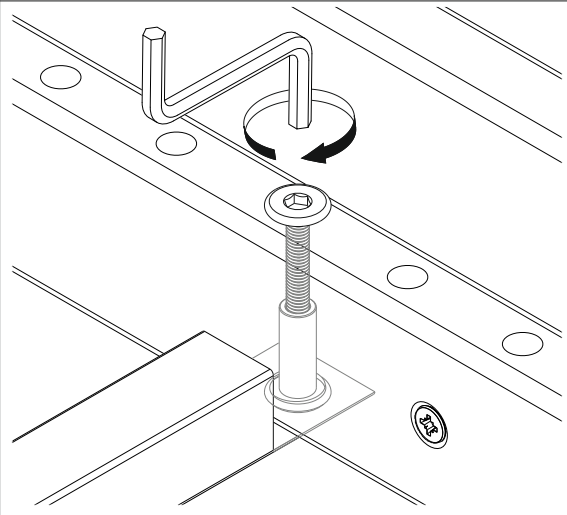
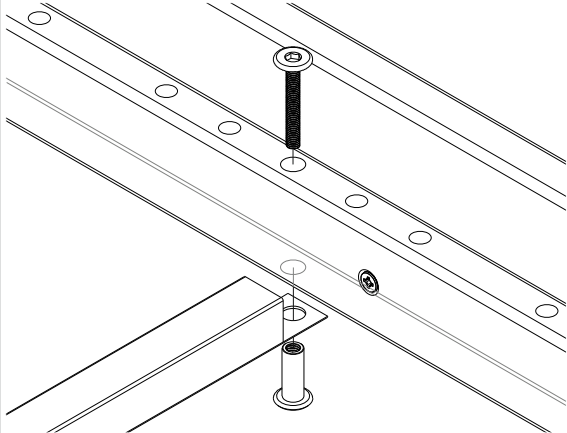
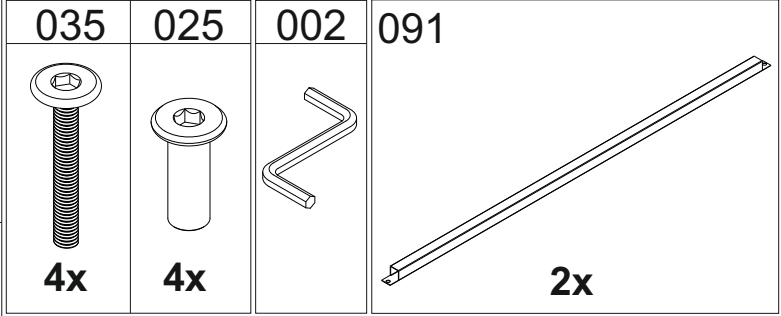
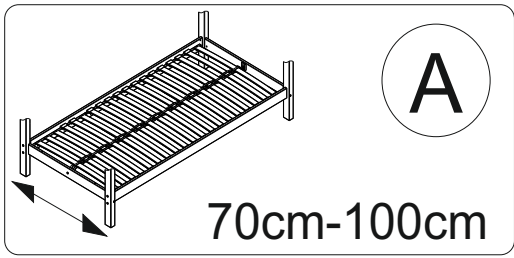

12

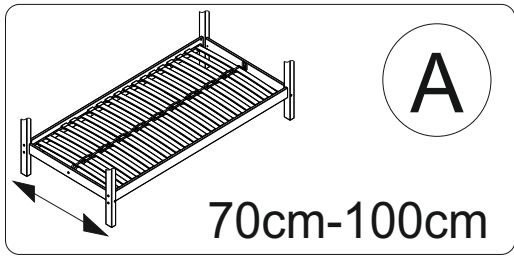

092

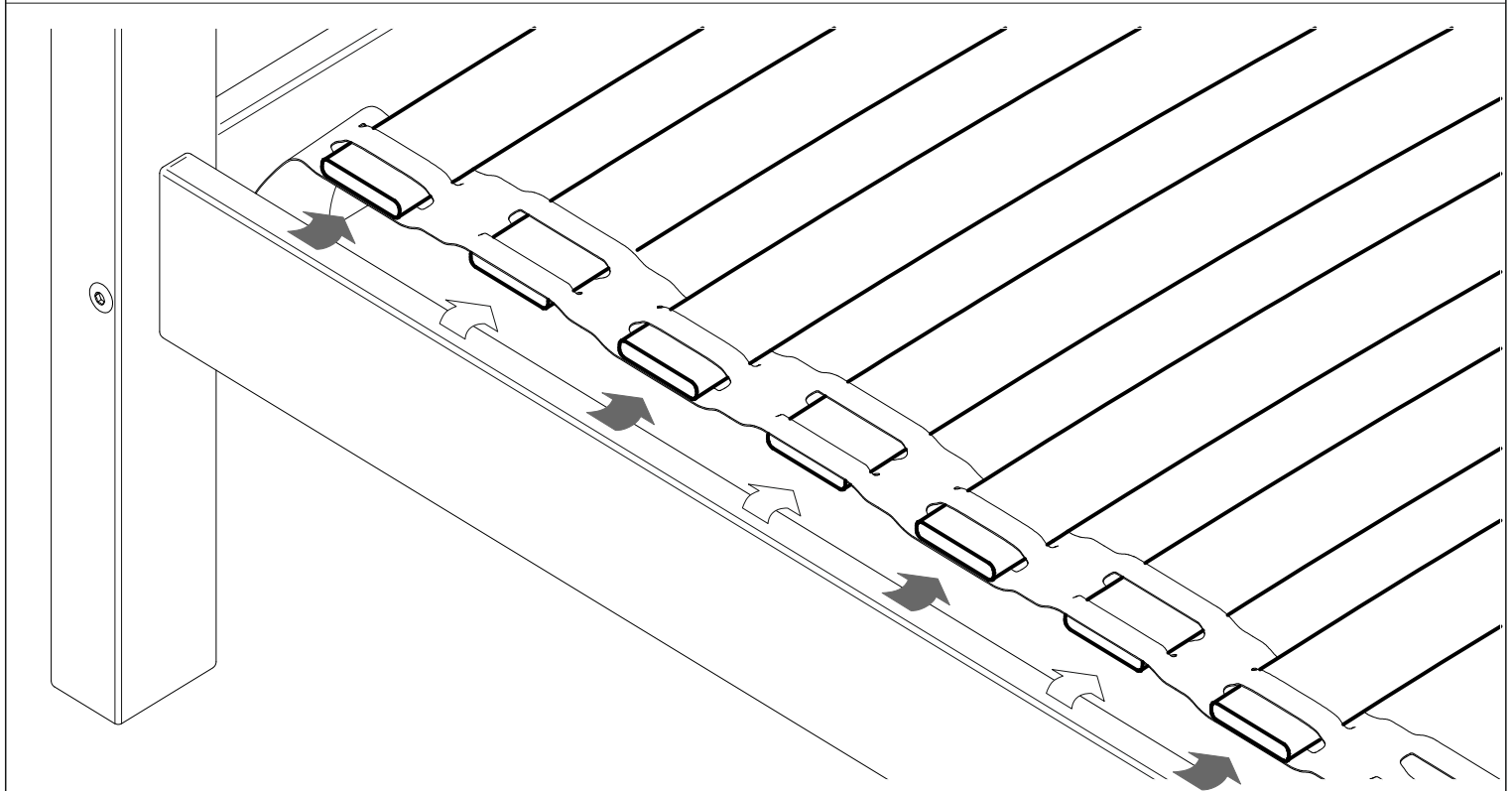
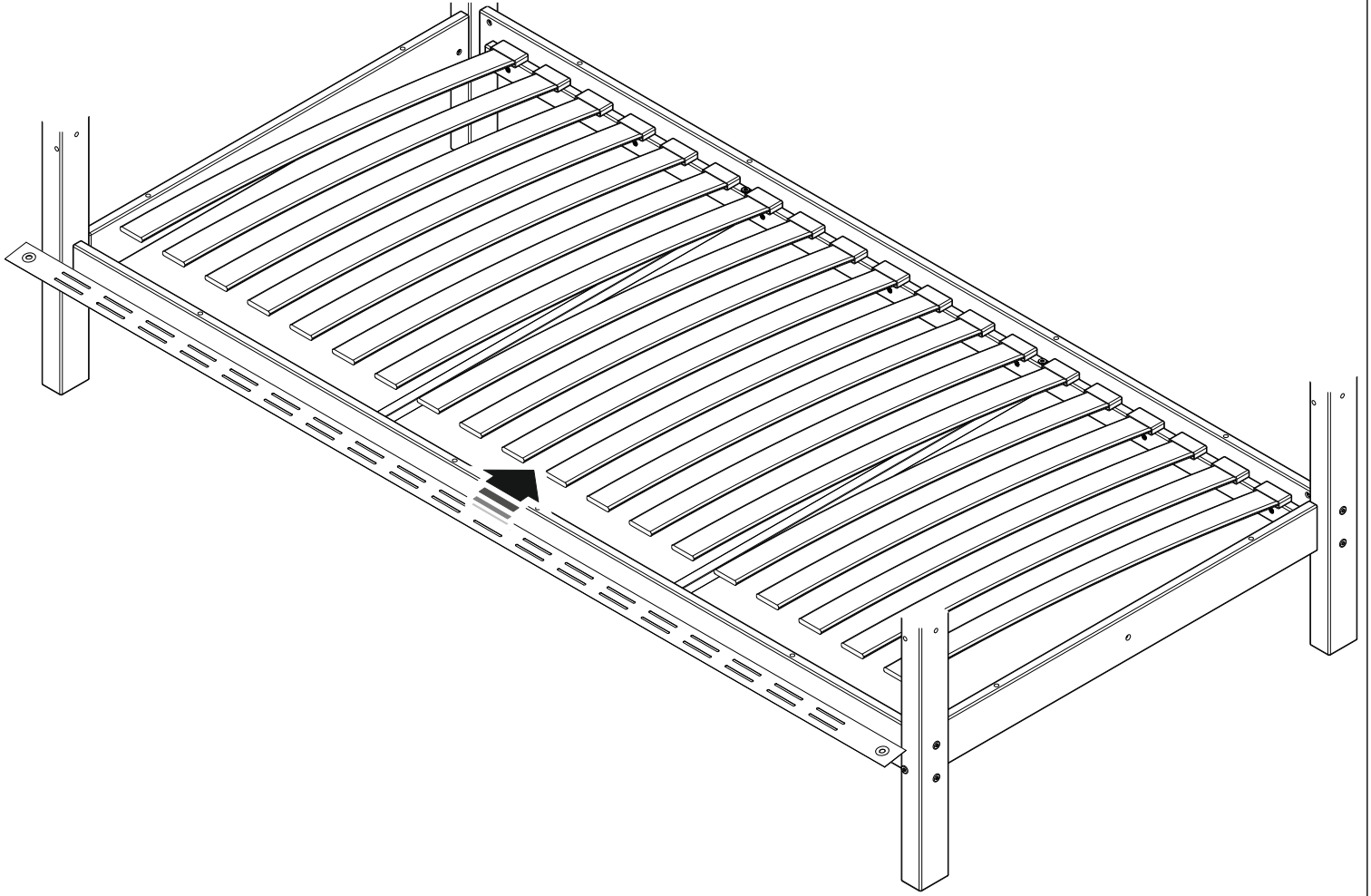
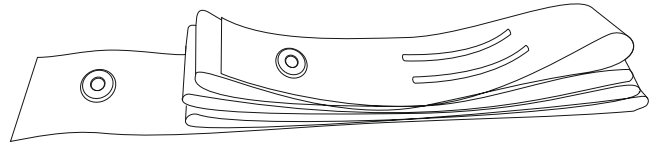

055

13

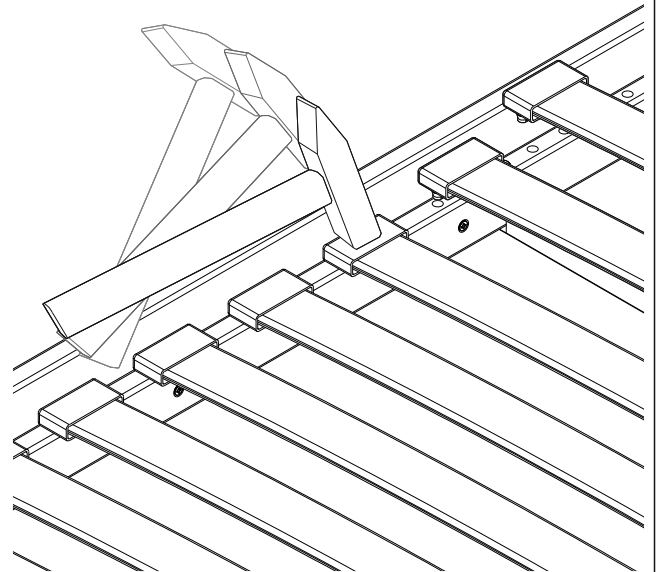
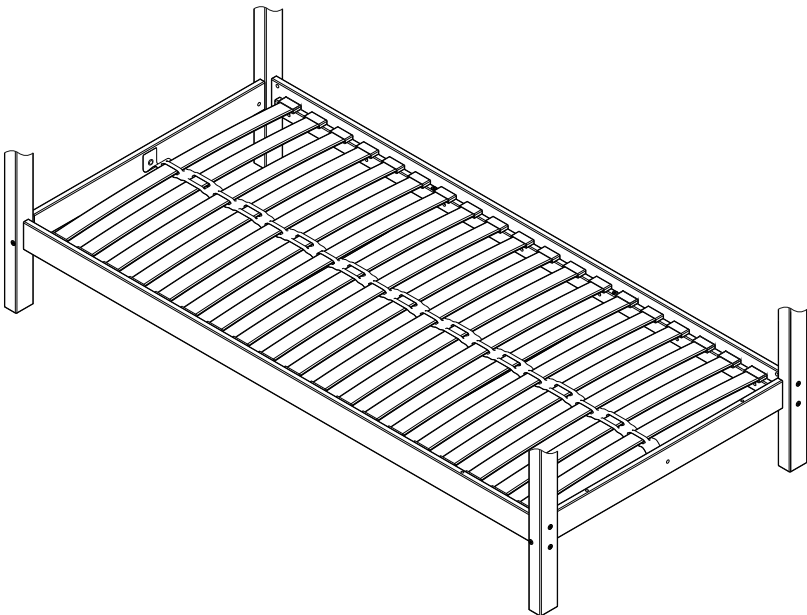
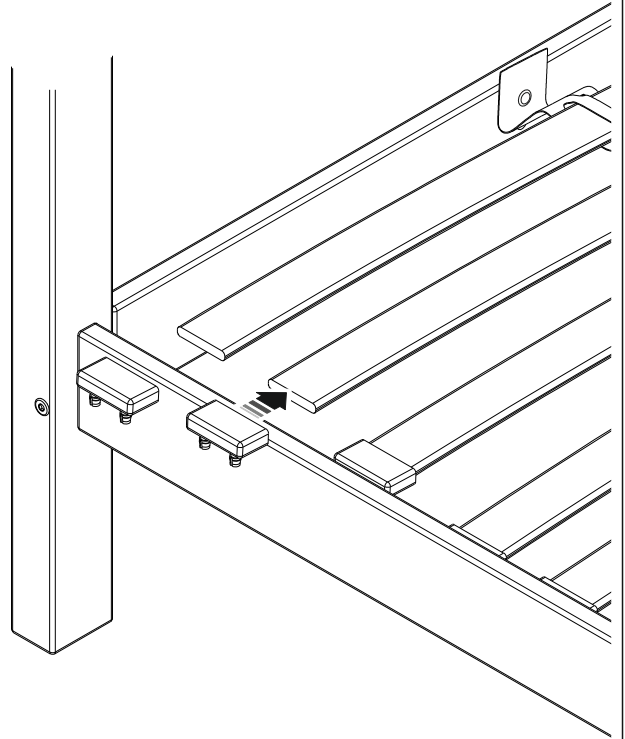
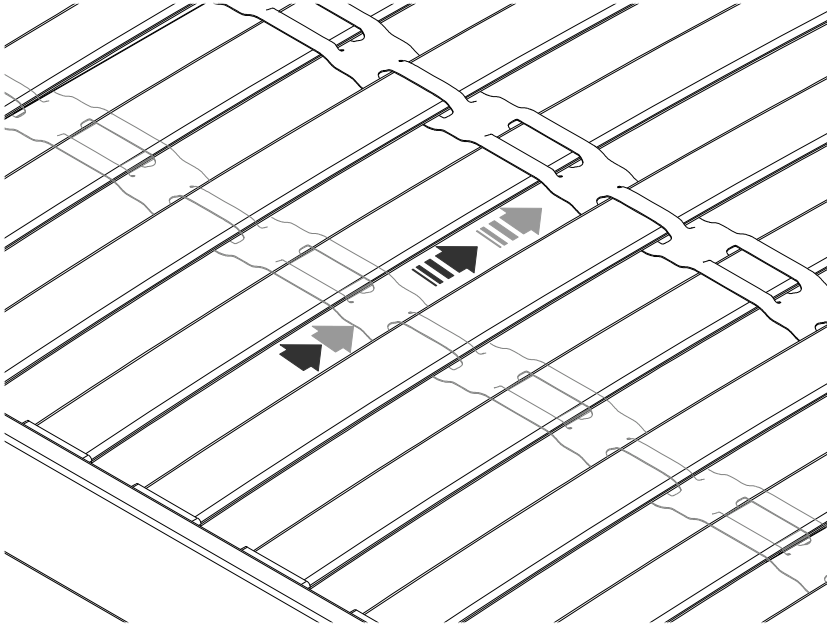
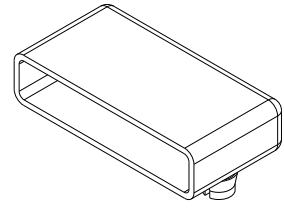
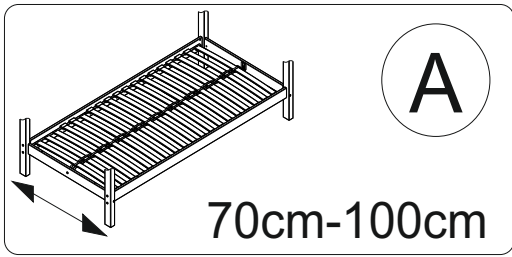

14

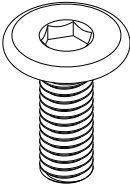
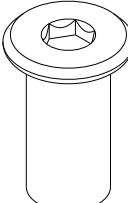
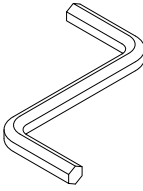
017	018	002
		
2x	2x	

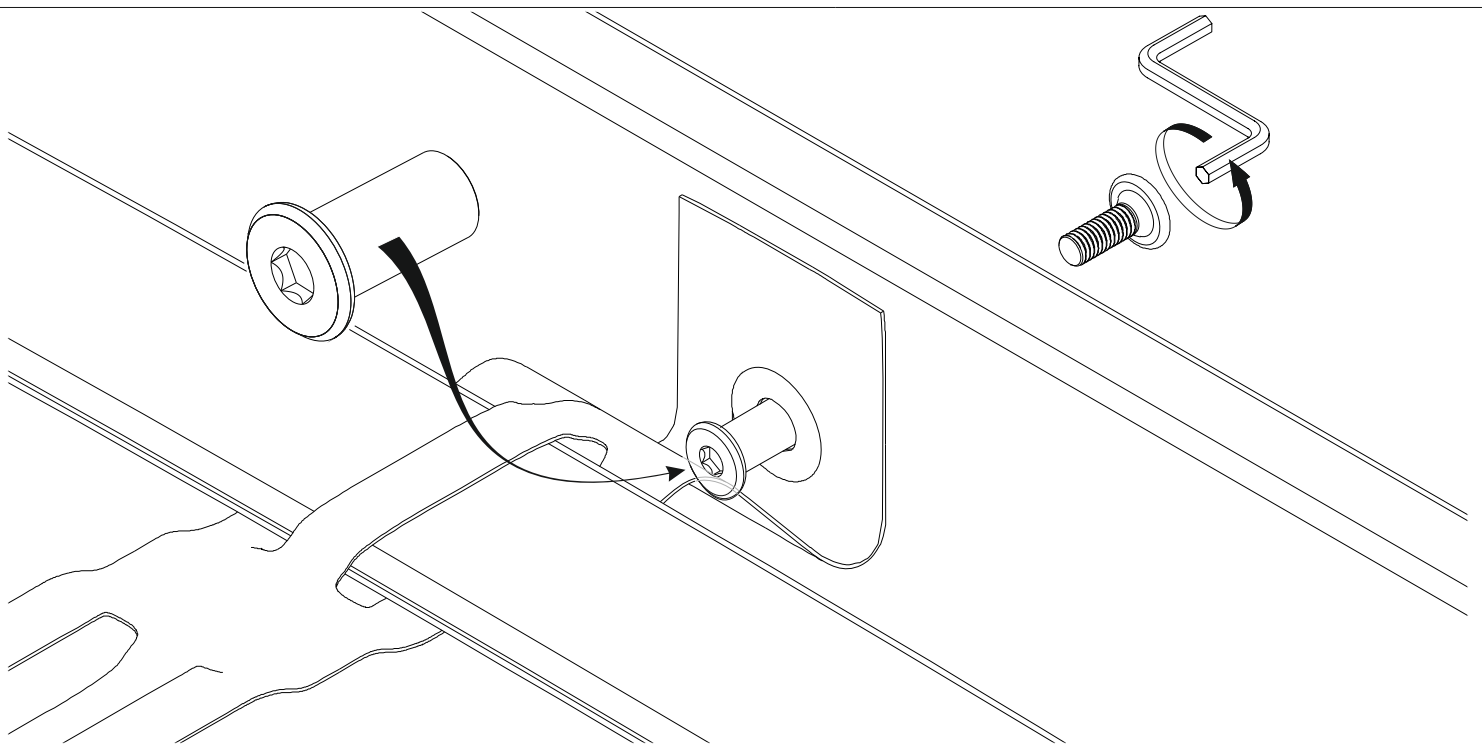
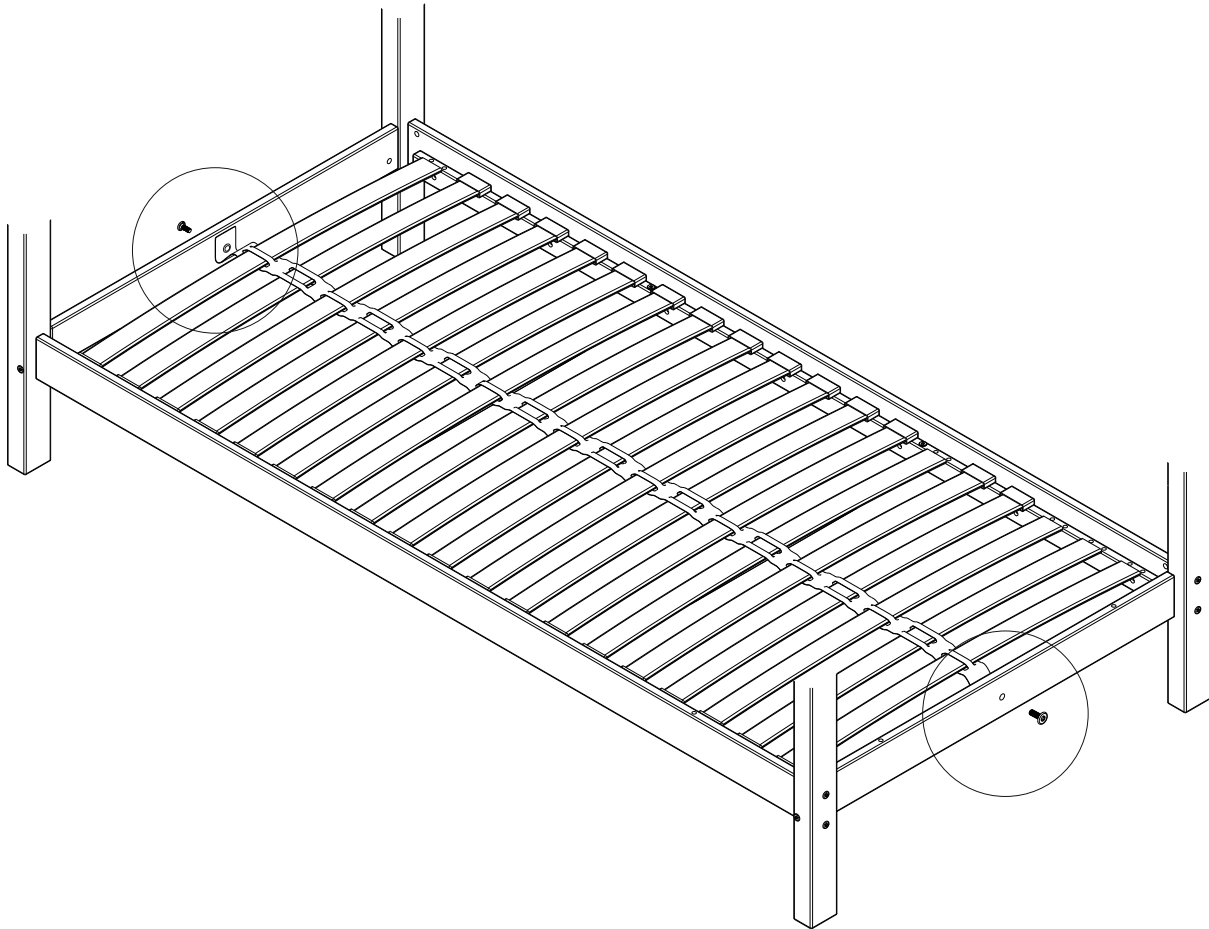
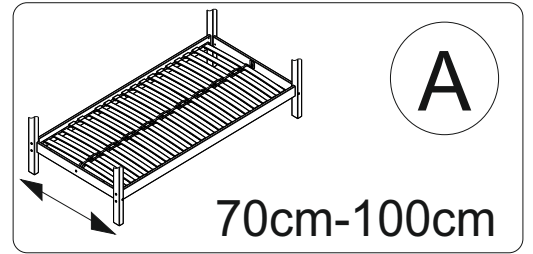

033

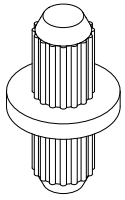

098

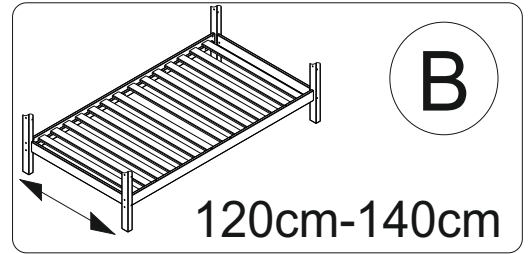
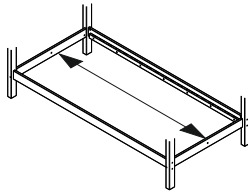
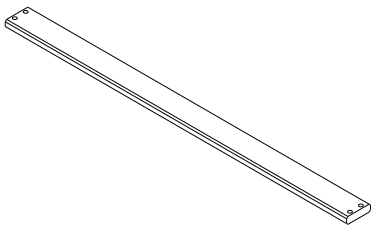

56x

14x

190cm

60x

15x

200cm

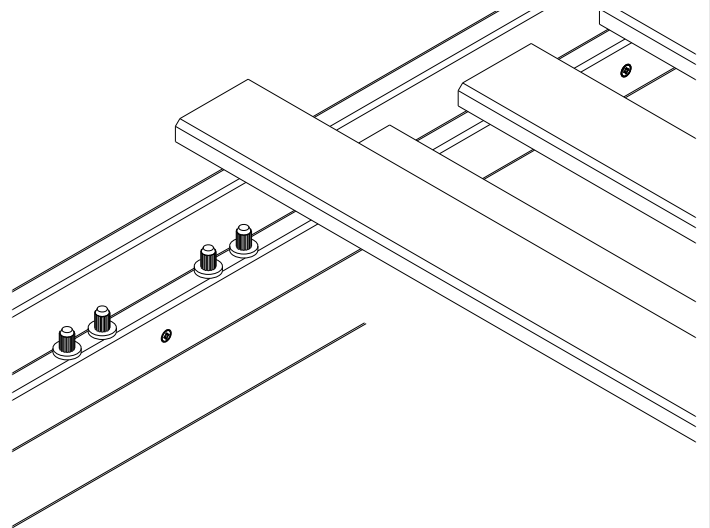
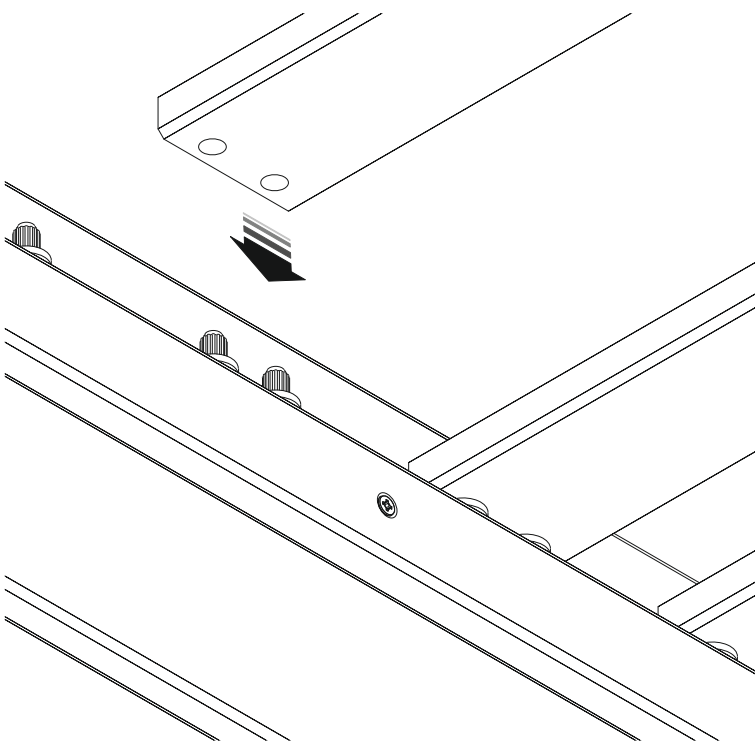
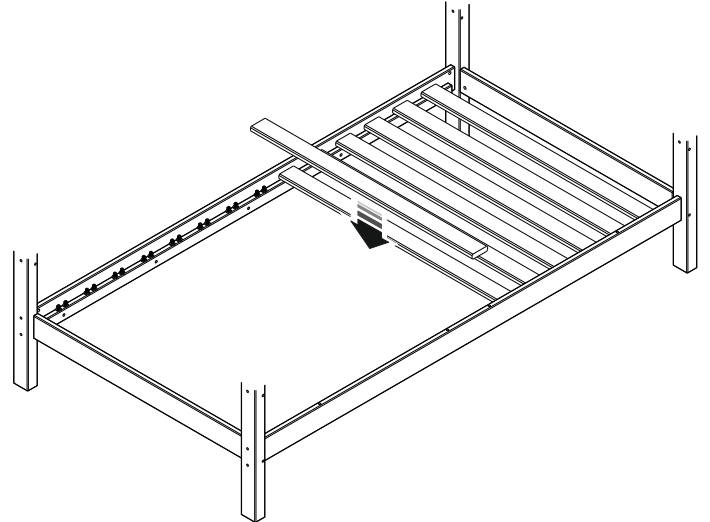
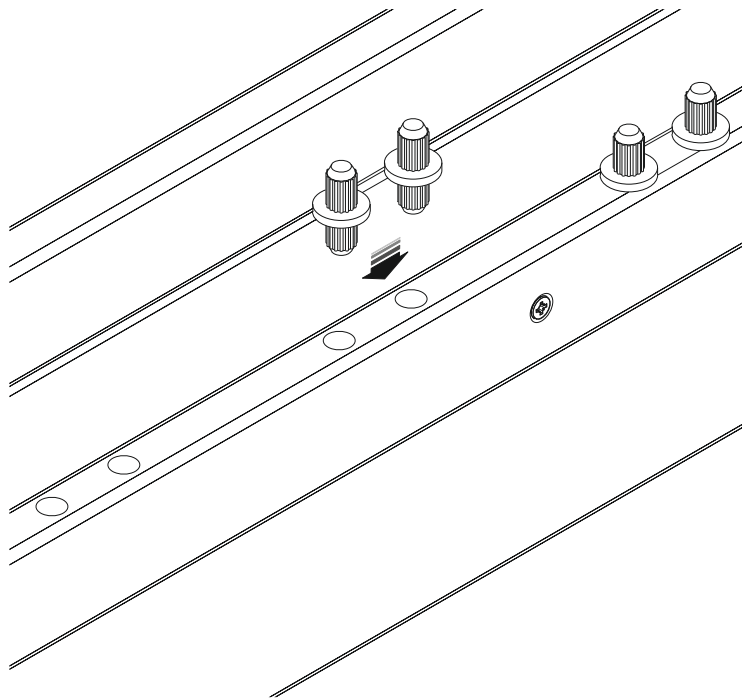

16

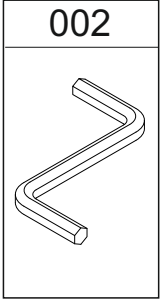
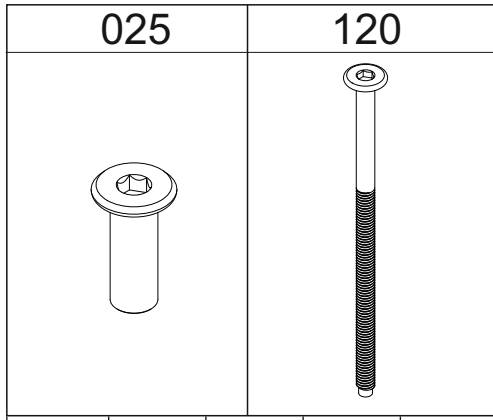

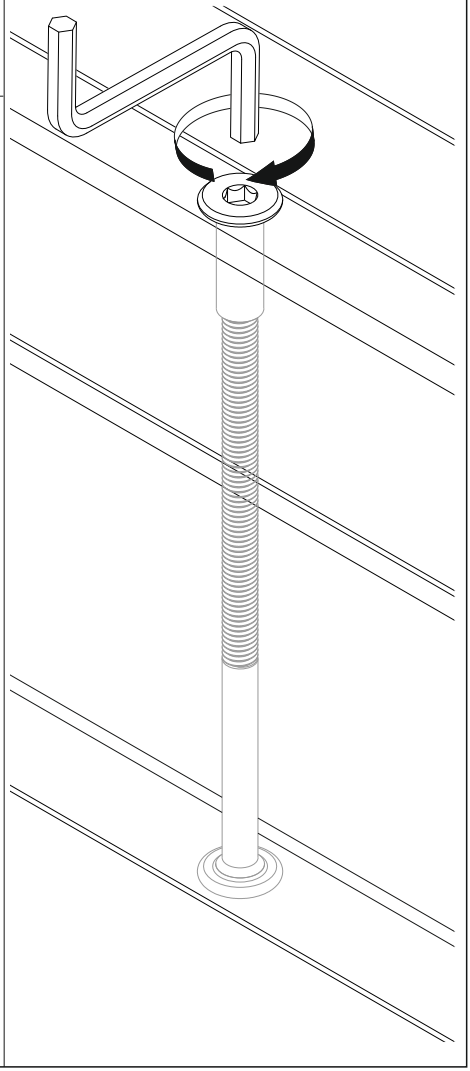
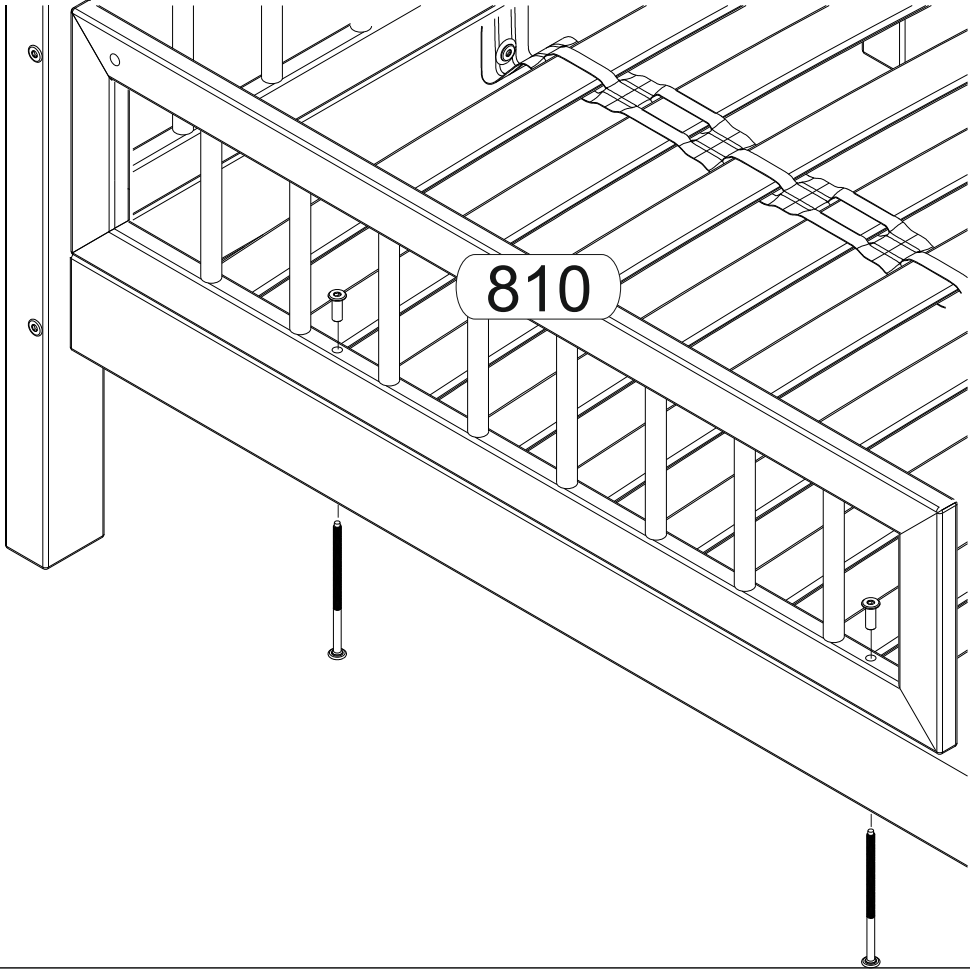
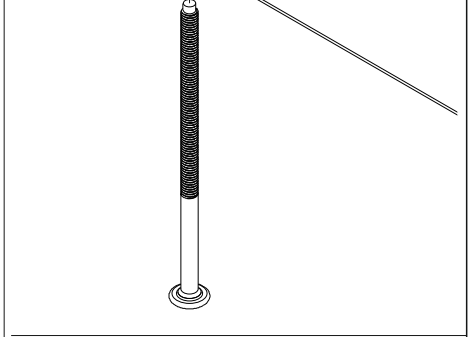
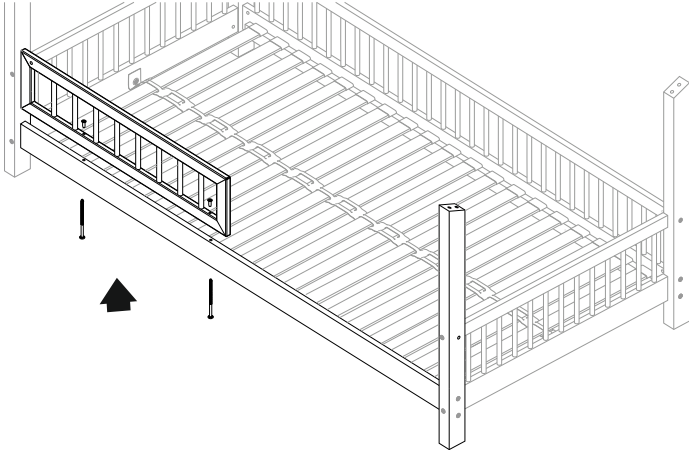
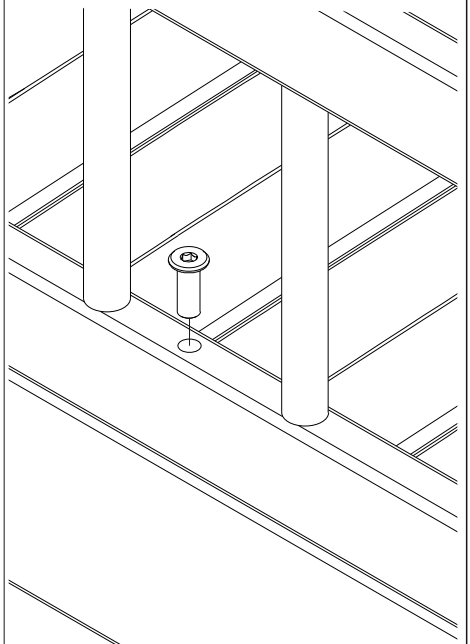
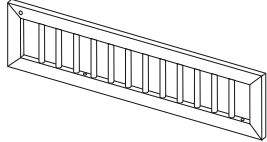

	140cm	160cm	180cm	190cm	200cm
$\frac{1}{2}$	2x	2x	2x	2x	2x
$\frac{2}{3}$	2x	2x	4x	4x	4x
$\frac{3}{4}$	2x	4x	4x	4x	4x

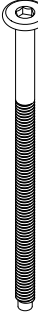
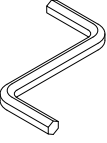

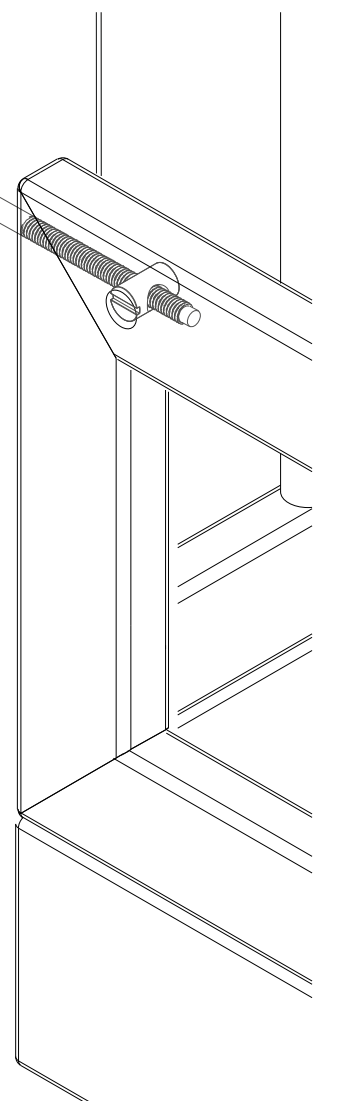
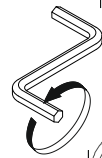
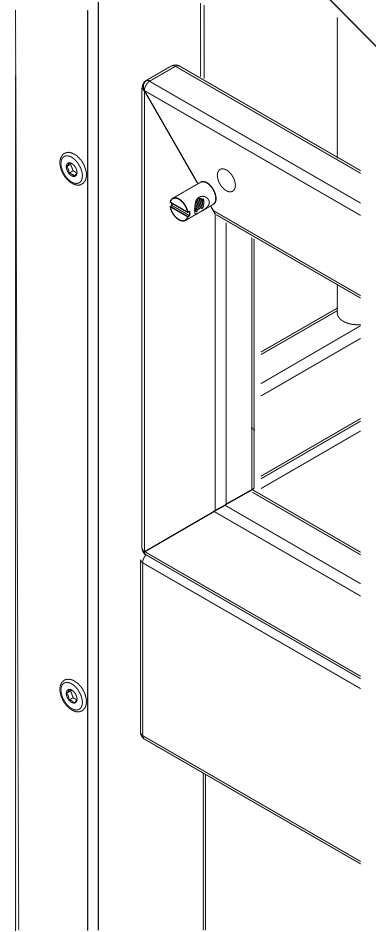
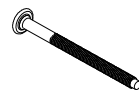
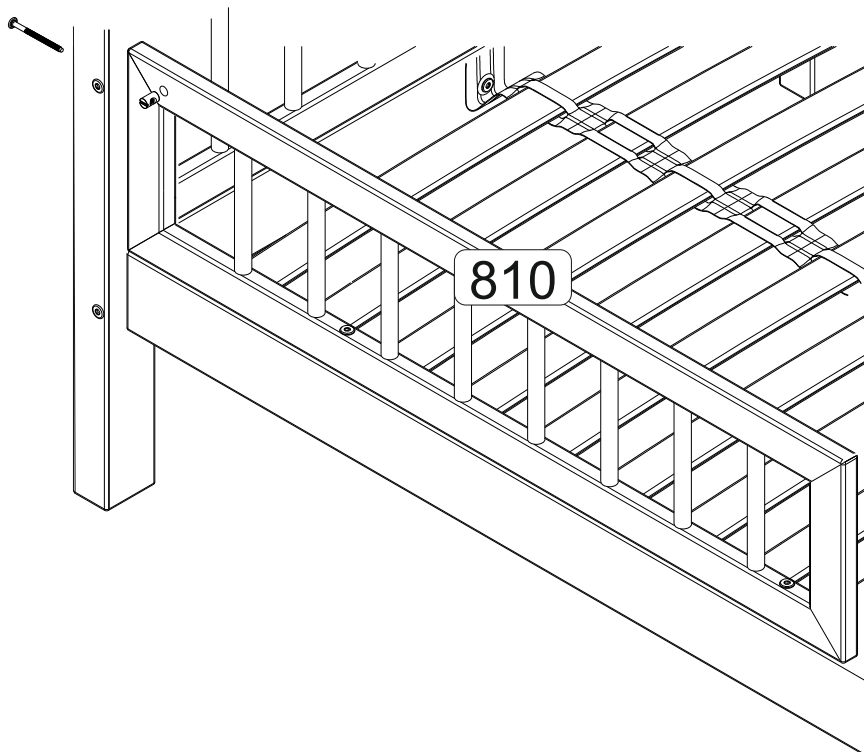
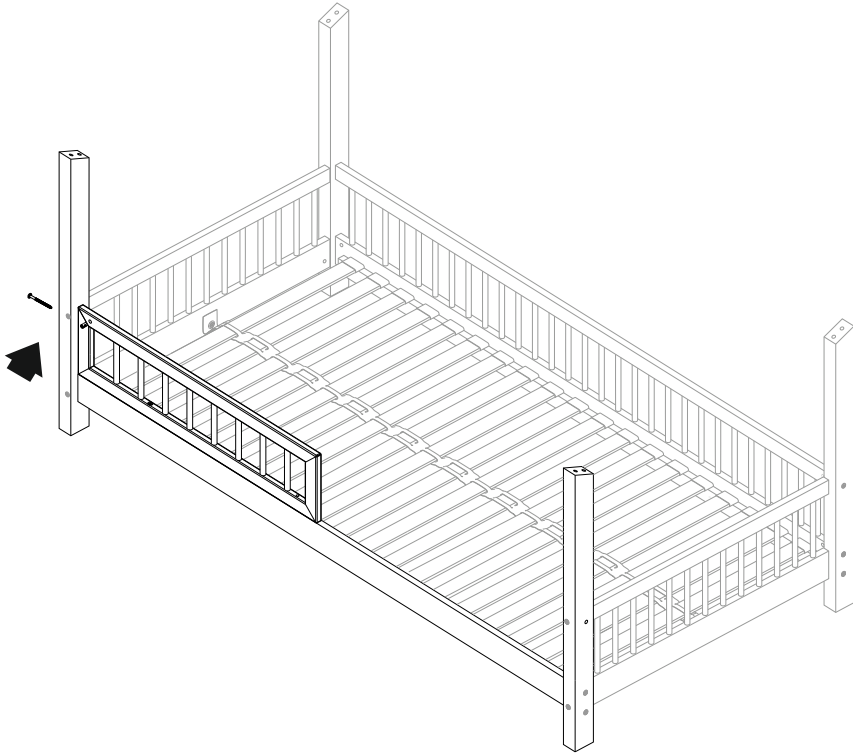
015	100	002
		
1x	1x	

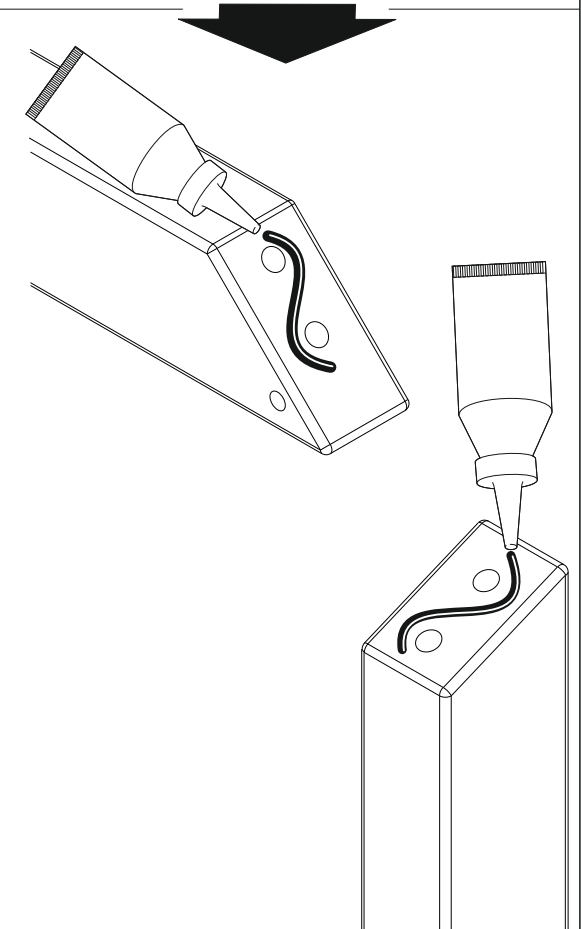
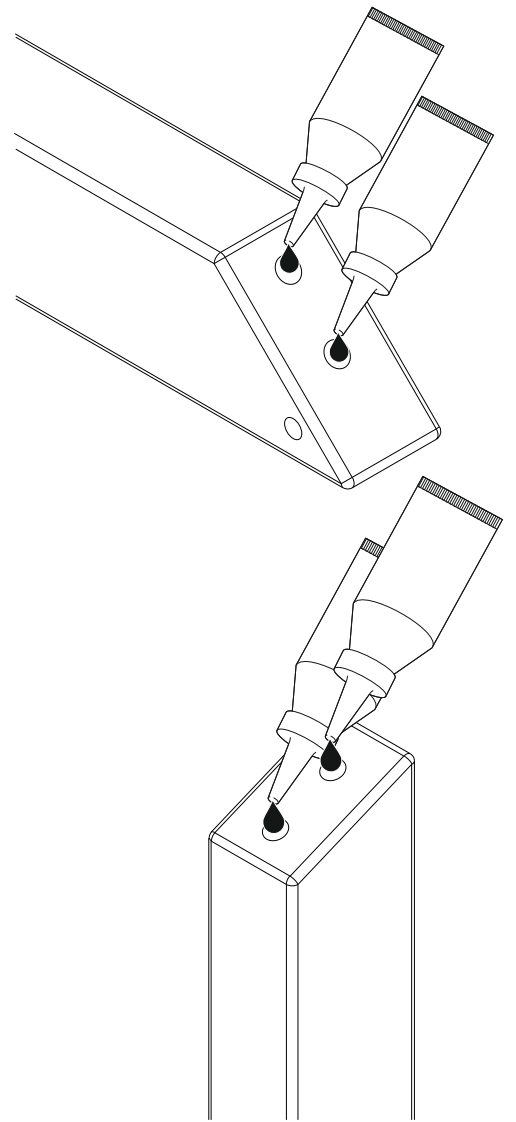
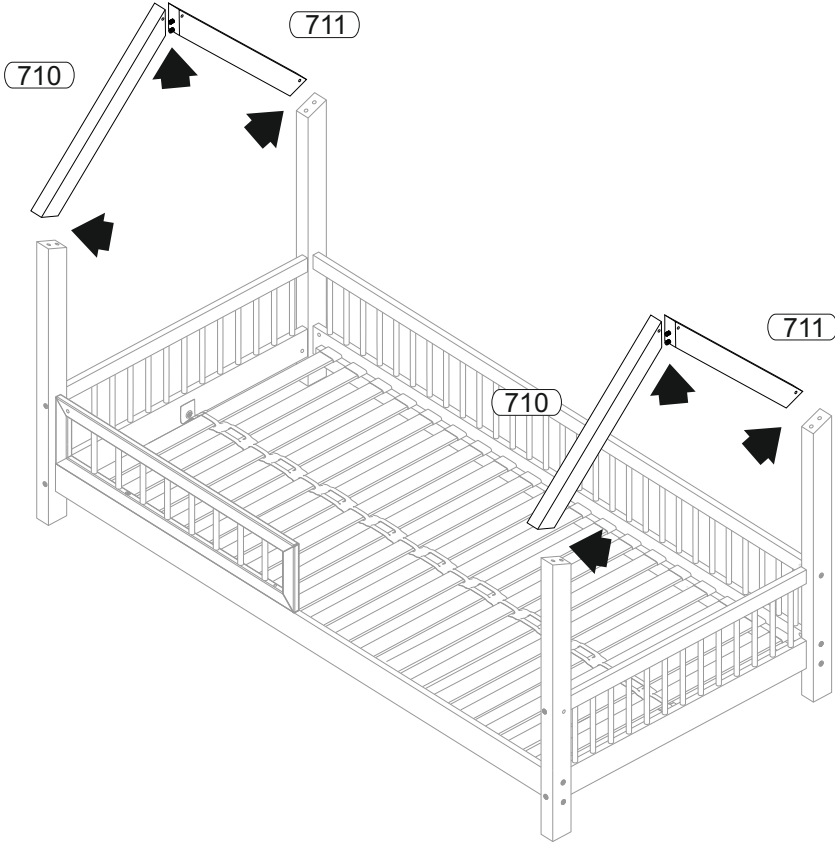
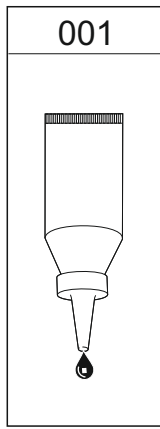

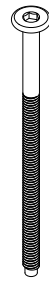
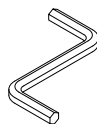

013	080	002
		
6x	6x	

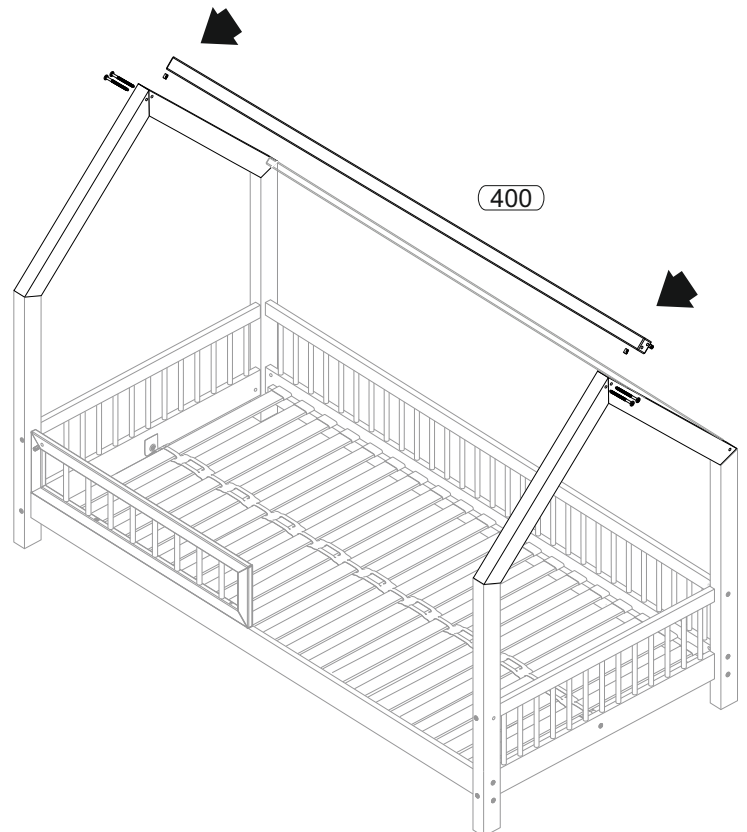
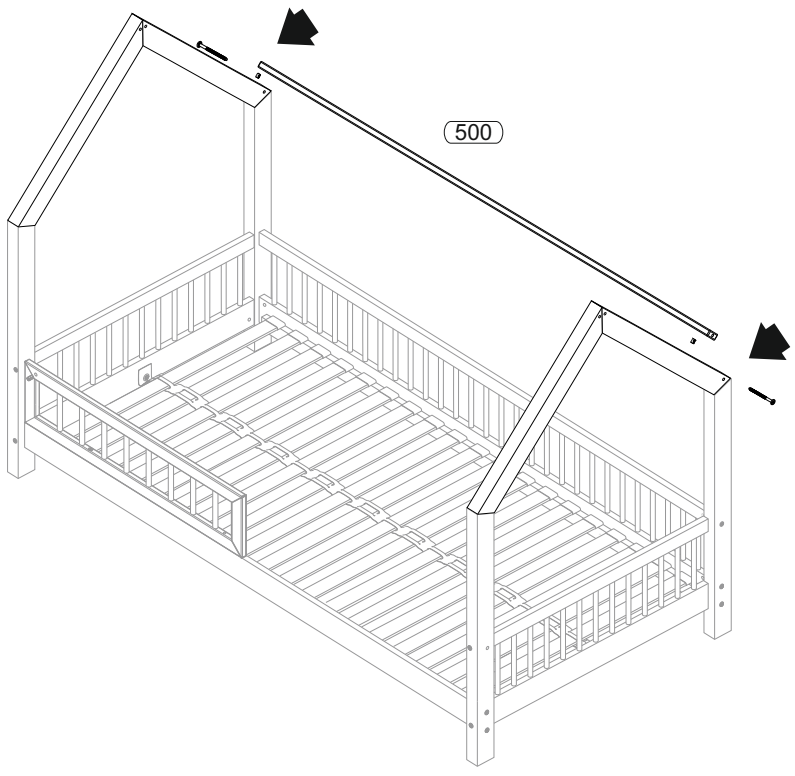
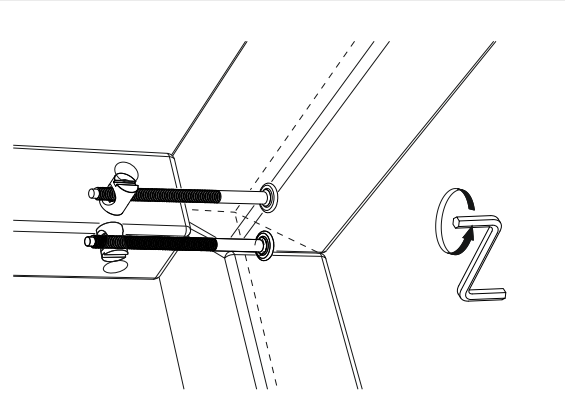
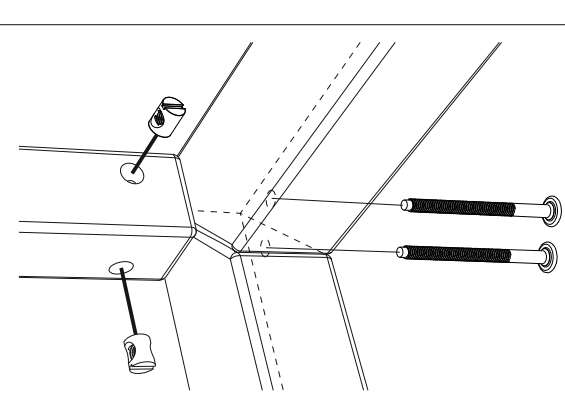
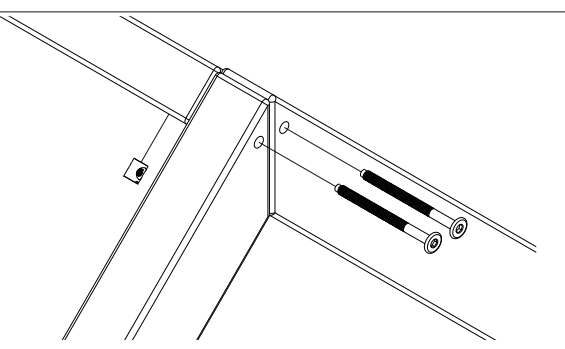
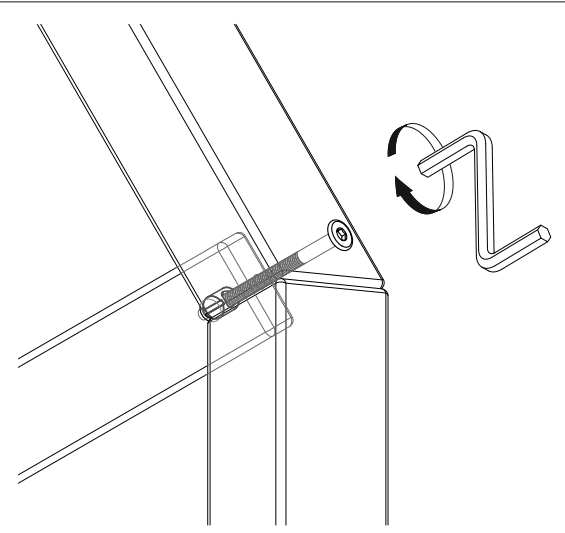
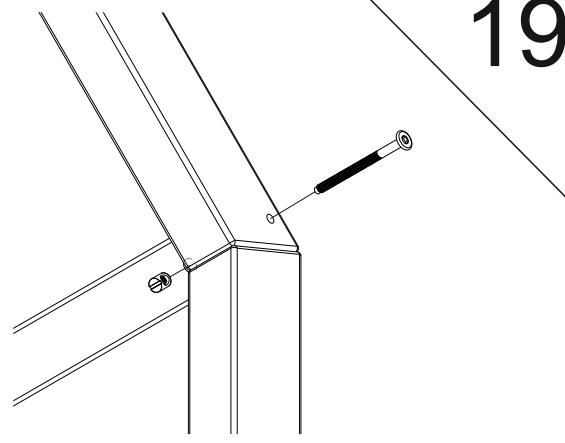



Produced by:
Jollyroom AB

Sörredsvägen 111
SE- 418 78 Göteborg
SWEDEN
Contact:
+46(0)31 310 00 00



Produced av:
Jollyroom AB

Sörredsvägen 111
SE- 418 78 Göteborg
SVERIGE
Konsumentkontakt:
+46(0)31 310 00 00



Produced av:
Jollyroom AB

Sörredsvägen 111
SE- 418 78 Göteborg
SWEDEN
Kundekontakt:
+47 33 50 93 50



Fremstillet af:
Jollyroom AB

Sörredsvägen 111
SE-418 78 Göteborg
SVERIGE
Kundeservice:
+45 88 44 88 88



Valmistuttaja:
Jollyroom AB

Sörredsvägen 111
SE- 418 78 Göteborg
RUOTSI
Asiakaspalvelu:
09-42 41 55 55



Hergestellt von:
Jollyroom AB

Sörredsvägen 111
SE- 418 78 Göteborg
SCHWEDEN
Kundeservice:
+49(0)40 2999 7999

www.jollyroom.com/contact

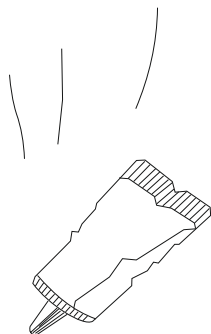

PLASTIC

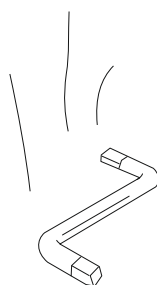

METAL

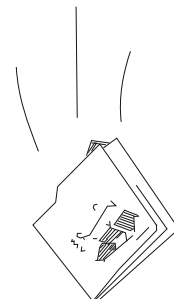

PAPER